



DOSATRON®

WATER POWERED DOSING TECHNOLOGY

20 m³/h - 100 GPM

D 20 S
D 20 SP
D 20 GL 2



manuel d'utilisation
owner's manual
gebrauchsanweisung
manuale d'uso
manual de utilización
gebruiksaanwijzing

Quick start-up

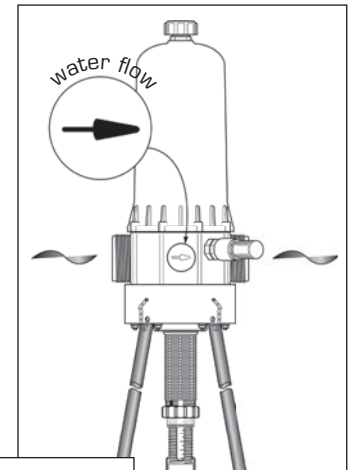
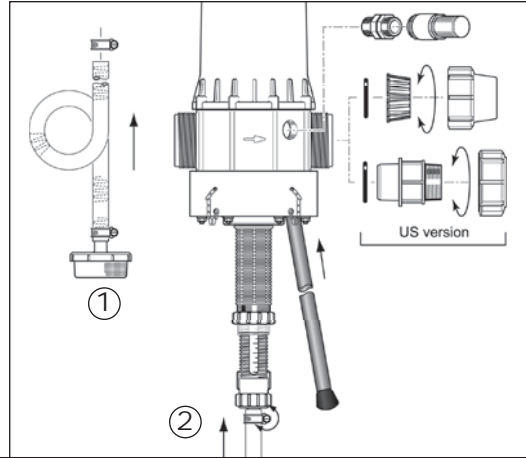

Maxi. : 32 clicks/15 sec.

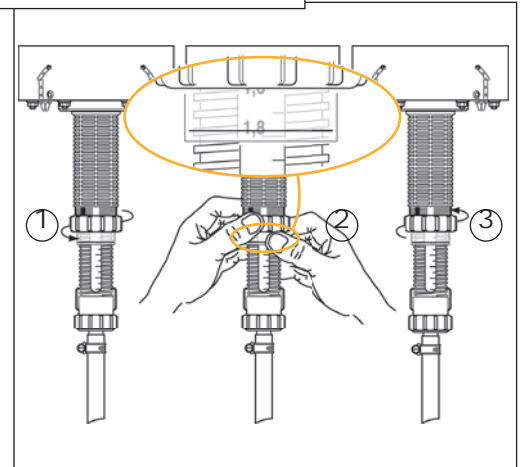
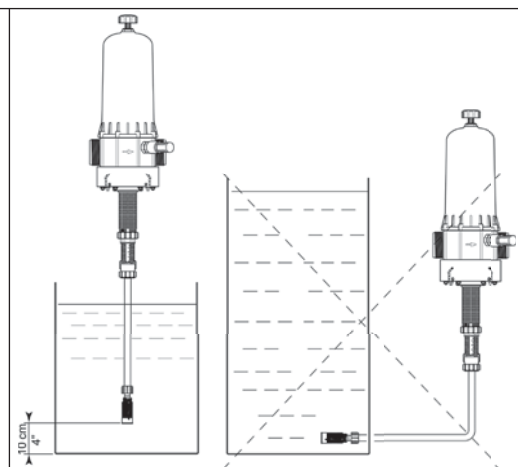
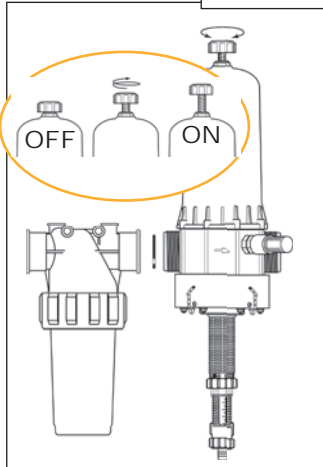

English

This document does not form a contractual engagement on the part of DOSATRON INTERNATIONAL and is for information only. Dosatron International reserves the right to alter product specification or appearance without prior notice.

© DOSATRON INTERNATIONAL S.A.S. 2009

You have just become the owner of one of the latest in the line of DOSATRON® proportional dosing pumps and we congratulate you on your choice.

The development of this model is the result of over 30 years experience. Our engineers have placed the Dosatron series at the forefront of technical development in the field of non-electric proportional dosing pumps. The choice of materials used in manufacture was most meticulous in order to resist chemical attack from the great majority of injectable products on the market. This Dosatron will, as time goes by, prove itself to be a most faithful ally.

A little care and attention, regularly spent, will guarantee you an operation in which the word breakdown has no place.

THEREFORE, PLEASE, READ THIS MANUAL CAREFULLY
BEFORE PUTTING THE DOSATRON INTO OPERATION.

Important !

The complete model reference and the serial number of your Dosatron is stamped on the pump body.

Please record this number in the space below and refer to it when you call your distributor for information, parts, and service.

Ref. #

Serial #

Purchase Date

SPECIFICATIONS

D 20 S / D 20 SP / D 20 GL 2

Practical operating **flow range**: **1 m³/h mini - 20 m³/h maxi**
[5 US GPM - 100 US GPM]

Operating **pressure**:

bar	0.12 - 10
PSI	2 - 120

Externally adjustable injection rate:

%	0.2 - 2
ratio	1:500 - 1:50

Concentrated additive injection:

Mini l/h - Maxi l/h	2 - 400
US Fl. oz/min	0.009
US GPM/max	1.75

Maximum operating temperature: **40 ° C** [104 ° F]

Connections (NPT/BSP male): **Ø 50x60 mm** [2" M]

Hydraulic motor capacity (for every 2 clicks of the piston) :
about **5 l** [1.32 US Gallons]

NOTE: The Dosatron is not preset,
see chapter ADJUSTING THE INJECTING RATE

UNIT SIZE

Diameter: cm ["]	17 [6 5/8]
Total height: cm ["]	132 [52] with legs
Width: cm ["]	38 [14 3/4]
Weight: ± kg [lbs]	18 [39.6]
Packaging size: cm ["]	100 x 43 x 34 [40 x 17 x 14]
Packaging weight: ± kg [lbs]	23 [50.7]

COMPOSITION DU COLIS : 1 Dosatron / 1 a support legs for
Dosatron / 1 suction tube of concentrated additive 180 cm [71"] -
Ø 20 x 27 mm [7/8" id x 1 1/16"]/ 1 strainer/ 1 vacuum breaker
device + connection / 1 owner's manual

Summary

INSTALLATION	PAGE
Precautions	8
Assembling the Dosatron	10
Installation hints	15
PUTTING INTO ORDER	
Using for the first time	16
Incorporated hydraulic By-Pass	16
Automatical anti-siphoning device	17
MAINTENANCE	
Recommendations	18
How to drain the Dosatron	18
International conversions	19
Fitting the suction tube	19
Adjusting the injection rate	19
Changing seals in the injection assembly	20
Cleaning and reassembling the suction valve	22
REFERENCE DESIGNATION	23
TROUBLESHOOTING	24
LIMITED WARRANTY	26

Precise, simple and reliable

Installed directly in the water supply line, the Dosatron operates by using water pressure as the power source. The water activates the Dosatron, which takes up the required percentage of concentrate. Inside the Dosatron, the concentrate is mixed with the water. The water pressure forces the solution downstream. The dose of concentrate will be directly proportional to the volume of water entering the Dosatron, regardless of variations in flow or pressure which may occur in the main line.

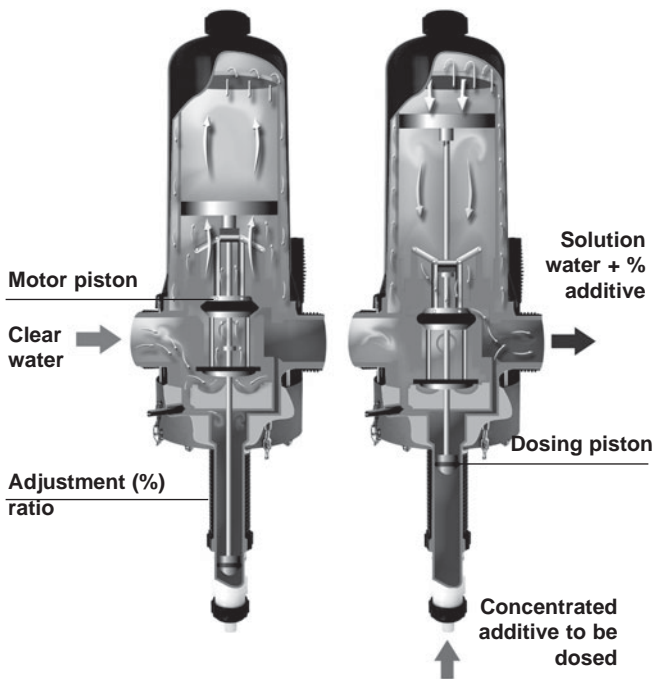

Installation

PRECAUTIONS

1 - GENERAL REMARKS

- **When connecting a Dosatron either to the public water supply or to its own water source, you must respect the regulations in force concerning protection of the source i.e. backflow prevention, etc.**

- When connecting the Dosatron to the water supply, ensure that the water flows in the direction of the arrows on the unit.

- In a case where the water installation is higher than the Dosatron itself, there is a possible risk of water and concentrate flowing back through the Dosatron. In this case, installing a non-return valve downstream is recommended.

- It is recommended that you should place an anti-siphon valve on the downstream side of the dosing pump in installations in which there is a risk of siphoning.

- Do not install the Dosatron just above an acid container, (risk of acid fumes attacking the Dosatron) and protect it from possible contact with corrosive products.

- Protect the Dosatron from freezing temperatures by draining it and store it away from sources of excessive heat.

- Do not install the Dosatron on the suction side of the supply pump (risk of siphoning).

- During any intervention the operator must stay in front of the Dosatron and wear protective eyewear and gloves.

-  **IMPORTANT !** Use no tool or metallic utensils.

- It is the responsibility of the owner/operator to replace the injection seals annually to ensure precise injection.

- The setting of the Dosatron's dosing rate is the sole responsibility of the user. The user has to respect the recommendations given by the manufacturer of the chemical product.

- It is the responsibility of the owner/operator to check that the flow and pressure of the installation do not exceed the Dosatron characteristics.

- Adjustment must be made when there is no pressure in the Dosatron. Turn off the water supply and allow the pressure to drop to zero.

- It is the responsibility of the owner/operator of the Dosatron, to determine the correct amount of solution and injection ratio to obtain the desired result.

- An air inlet, an impurity or a chemical attack on seal can interrupt the dosing function. It is recommended to periodically check that the solution is being correctly drawn up into the Dosatron.

- Change the suction tube as soon as it seems damaged by the chemical.

- Relieve the pressure after use (advised).

- Rinsing of the Dosatron is required :

. when changing chemicals,

. before handling the Dosatron, to avoid any contact with the chemical.

PRECAUTIONS (cont...)

1 - GENERAL REMARKS (cont...)

- Before applying any aggressive chemicals, please consult your distributor to confirm compatibility with the dosing pump.
- All assembly should be done without tools, hand tighten only.

2 - WATER WITH HIGH PARTICLE CONTENT

- A (ex.: 50 mesh - 300 microns depending on your water quality) water filter must be installed upstream from the Dosatron (see accessories), if a filter is not installed abrasive substances will cause the Dosatron to deteriorate prematurely.

3 - WATER-HAMMER / EXCESSIVE FLOW

- For installations subject to water hammer a protection device such as a check valve or union ball check must be fitted (pressure/flow control system).
- For automatic installations, slow opening and closing solenoid valves are preferable.
- In an installation where a Dosatron serves several sectors, the closing of one sector and the opening of another sector must be done at the same time (simultaneous operation of the solenoid valves).

4 - INSTALLATION LOCATION

- The location of the Dosatron and concentrate container should be accessible, but should never present a risk of pollution or contamination.
- It is recommended to label all water lines with a warning about the injected solution i.e. Not For Human Consumption.

5 - MAINTENANCE

- Rinse the injection areas after using the Dosatron. To do this, insert suction tube into a container of clean water and inject about 1 liter [0.264 US Gallons].
- Routine maintenance once a year will add to the life of your Dosatron. Replace the dosing seals as well as the suction tube annually to ensure proper injection.

6 - SERVICE

- This Dosatron was tested prior to packaging.
- Complete maintenance and seal kits are available.
- Call your DOSATRON® distributor for service or parts.

ASSEMBLING THE DOSATRON

ASSEMBLY SHOULD BE CARRIED OUT WITHOUT THE USE OF TOOLS

Model D 20 S

The Dosatron is delivered with:

- a support legs,
- a suction tube with strainer,
- a vacuum breaker + connections.

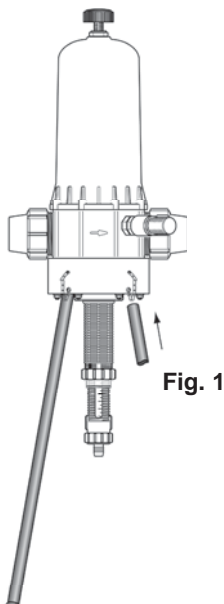

- Insert the legs in the hoses (**Fig. 1**).
- Fix them with the 4 pins.

ASSEMBLING THE DOSATRON (cont...)

All models

- Remove the nuts (**Fig. 2-A**) and ferrules (**Fig. 2-C**) from the Dosatron inlet and outlet.
- Remove the plastic caps (**Fig. 2/3-B**) which block the inlet and outlet of your Dosatron before connecting to the water supply.
- Make sure the watertight seals at the inlet and outlet of the Dosatron are correctly positioned.
- Make certain that the water flows in the direction of the arrows on the pump body.
- Wrap the thread of the nipple with Teflon.
- Screw the nipple (**Fig. 3-M**) into the vacuum breaker (**Fig. 3-V**).
- Screw the whole assembly onto the dosing unit (**Fig. 3**).

NOTE : The Dosatron is shipped in OFF position (see § “Incorporated bypass”).

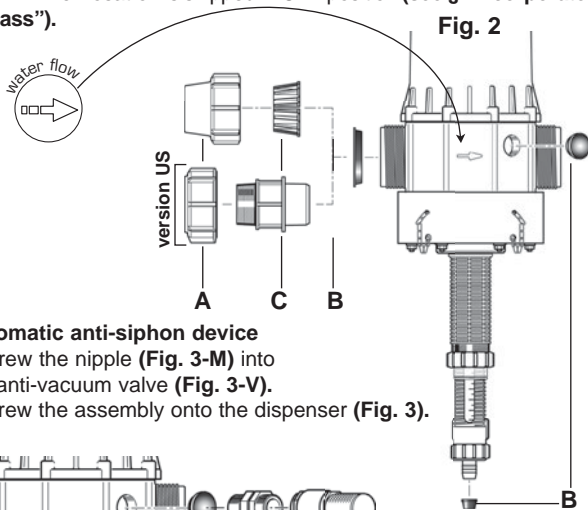

Automatic anti-siphon device

- Screw the nipple (**Fig. 3-M**) into the anti-vacuum valve (**Fig. 3-V**).
- Screw the assembly onto the dispenser (**Fig. 3**).

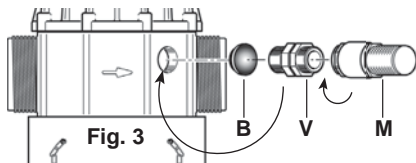

RECOMMENDATIONS

- In order to avoid electrolysis phenomena, it is advised to earth your Dosatron.

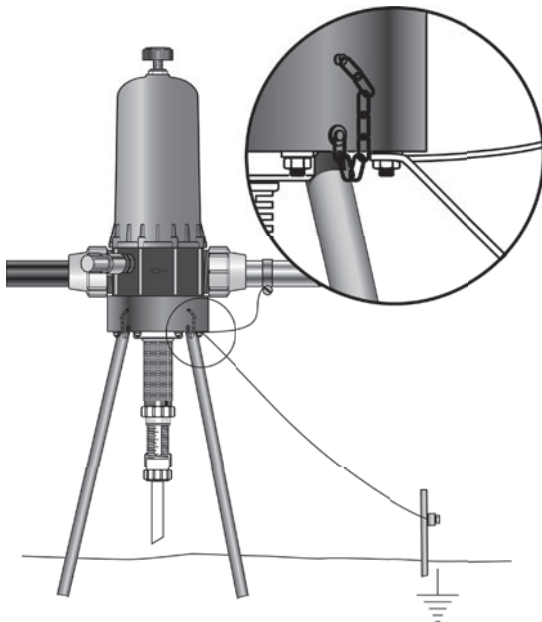

ASSEMBLING THE DOSATRON (cont...)

For connecting to polyethylene or polypropylene pipe :

- Bevel the end of the pipe and slide on nut (**Fig. 4-E**) and then ferrule (**Fig. 4-C**).
- Slide pipes into water inlet and outlet (**Fig. 4**) as far as they will go.
- Push one ferrule (**Fig. 4-C**) against the inlet and the other against the outlet.
- Tighten the nuts (**Fig. 4-E**).

For connecting to PVC pipe :

- Proceed as for the polyethylene and polypropylene pipes but spread PVC adhesive on the pipe where the ferrules are to be mounted.
- Then place the ferrules over the pipe using both thumbs in the slot to widen the ferrule (**Fig. 4-C**) and avoid scraping off the adhesive, then tighten the nut.

NOTE : Wait for one hour before putting into operation.

The ferrule made of polyacetal will not adhere to the PVC glue and can therefore be dismantled easily at a later date.

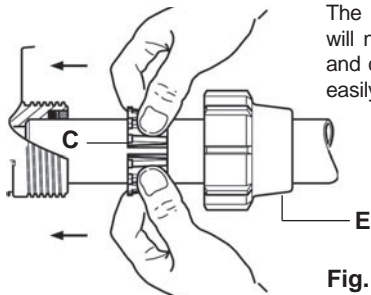

Fig. 4

The connection of the Dosatron to the water network can be done with flexible hoses (internal diameter 50 mm) to be fixed by means of clamps and turning adapters \varnothing 50 x 60 mm [2"]. Make sure the water is flowing according to the direction arrow on the pump body.

The Dosatron is delivered with a suction hose (cut it to the needed length) enabling its use with a large capacity concentrate container.

The hose must be fitted with its strainer.

The instructions for fitting the hose are to be found in the specific chapter.

ASSEMBLING THE DOSATRON (cont...)

NOTE :(refer to § “Using for the first time”)IMPORTANT ! - Do not put the suction tube strainer on the bottom of the stock solution container. The strainer must be suspended at least 10 cm [4"] above the bottom of the tank to avoid sucking up the insoluble particles that may damage the injection assembly (Fig. 5).

- Do not put the strainer on the ground.

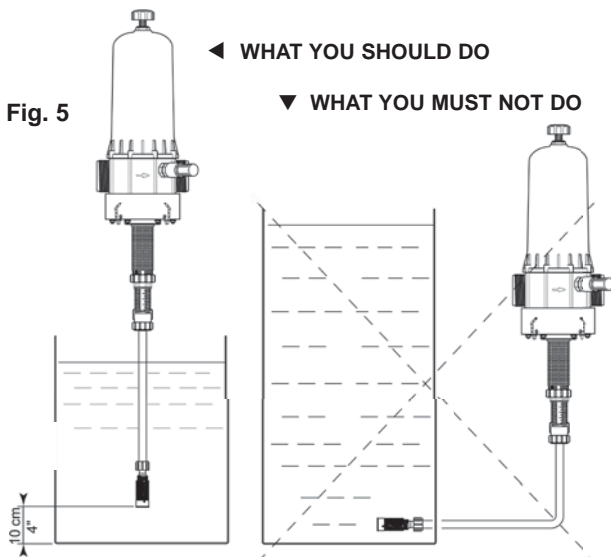

Under no circumstance should the solution level be above the water inlet of the Dosatron (to avoid siphoning situations).

INSTALLATION HINTS

The Dosatron can be connected to the main water line **directly** (Fig. 6) ; on a **by-pass** (Fig. 7), recommended.

If your flow rate is above the operating limits of the Dosatron, see § **EXCESSIVE FLOW**.

To prolong the working life of the Dosatron it is advisable to install a filter (ex.: 50 mesh - 300 microns depending on your water quality) upstream.

This is imperative if the water contains impurities or particles, especially if the water comes from a well.

A filter is recommended and required for the warranty to be valid.

Installing the Dosatron on a bypass enables clean water to be supplied without operating the Dosatron and the Dosatron to be easily dismantled.

When connecting an installation to the public water supply, you must respect the rules and regulations in force in the country.

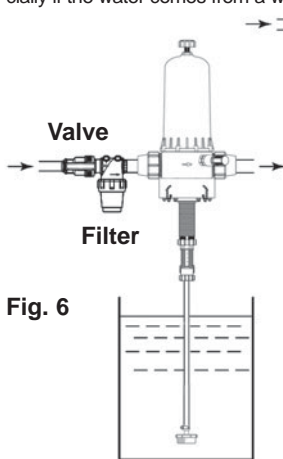

Fig. 6

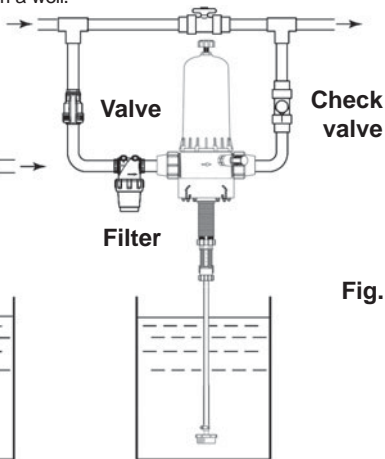

Fig. 7

Excessive flow (as an indication)

If your Dosatron clicks more than **32 times**, that is **16 cycles in 15 seconds**, you are close to the superior flow limit. If you need more flow, you must install a Dosatron with a superior capacity of flow.

Putting the DOSATRON into order

USING FOR THE FIRST TIME



The Dosatron unit comes on OFF position.

- Bring the bypass button (model D20S) into median position.
- Open the water inlet valve slowly, the Dosatron is self-priming.
- Operate the Dosatron until the product to be injected is drawn up into the injection stem (the product is visible through the plastic tube).
- The Dosatron makes a characteristic “click-clack” noise when working.

NOTE : The time required to prime the suction hose depends on the water flow-rate, the ratio setting and the length of the suction hose. To bleed the air from the suction hose and accelerate the priming, set the injection rate at maximum. Once the Dosatron is primed, adjust to the required injection rate (see § ADJUSTING THE INJECTION RATE).

INCORPORATED HYDRAULIC BY-PASS

A mechanism to select either the dosing function or the by-pass mode, only for D20S model:

- Completely unscrew the bypass button on the top of the unit (Fig.8-A), the Dosatron is working and sucking product.
- The dosing unit is operating (significant noise can be heard).

Bypass operation:

- Completely screw the bypass button (Fig. 8-C), the Dosatron stops (no more noise) and does not suck product any more. The water continues to flow through the unit.

ATTENTION : The median position is the draining position (Fig. 8-B). It is normal that the bypass screw is leaking when the bypass is in the median position.

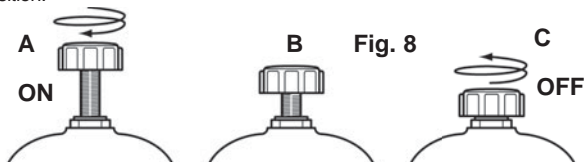

AUTOMATICAL ANTI-SIPHONING DEVICE

Automatic anti-siphon valve :

- This automatically recreates normal atmospheric pressure in the Dosatron in the event of an accidental vacuum in the line (**Fig. 9**)*.
- Its use depends on the regulations in force in your country.
- You must comply with the local water authority's requirements.

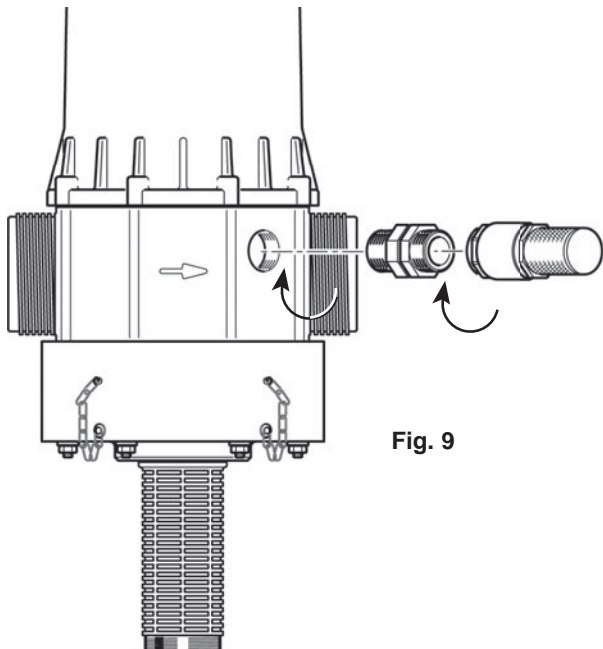

Fig. 9

*i.e.:

- if the water outlet is lower than the inlet.
- if the water cut-off is before the dispenser.

Maintenance

RECOMMENDATIONS

1 - When using soluble products to be made up into solutions, we recommend the periodic dismantling of the entire dosing part (see : § CHANGING SEALS IN THE INJECTION ASSEMBLY).

Thoroughly rinsing all the elements of the dosing part with water and re-assembling them after having previously lubricated the seal (Fig. 10) with a silicone lubricant, in the case of difficulty in re-fitting.

2 - An air inlet, an impurity or a seal's failure can interrupt the dosing function ; periodically check out that the concentrate is correctly drawn up, thus incorporated into the water.

3 - Before putting the Dosatron into operation after a non-use period, remove the motor piston and soak it into lukewarm water < 40° C [104° F] overnight. This helps to dissolve any deposits which may have dried onto the piston motor.

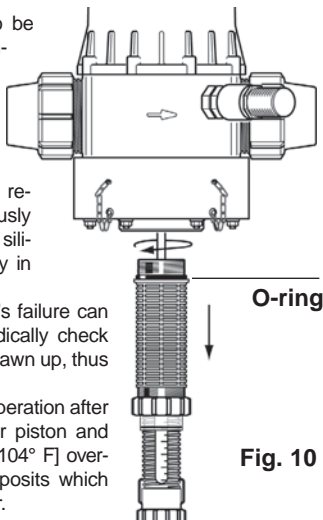

HOW TO DRAIN THE DOSATRON (in case of freezing temperature)

- Turn off the water supply and let the pressure drop to zero.
- Screw the bypass button into the median position.
- Remove the injection assembly.
- Disconnect the water inlet and outlet fittings.
- Also unscrew the bleed screw (Fig. 11-P), remove it and let the water flow out.
- Re-assemble in the reverse order

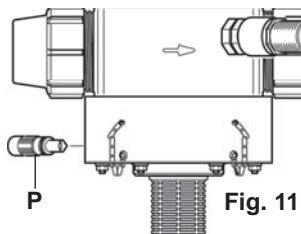

INTERNATIONAL CONVERSIONS

Principle : Setting at 1% \Rightarrow 1/100 = 1 part of concentrate for 100 parts of water.

Ex. : Setting at 2% \Rightarrow 2/100 = 2 parts of concentrate for 100 parts of water.

Ratio \Rightarrow 1/50.

FITTING THE SUCTION TUBE

If the Dosatron has already been used, please **imperatively** refer to § PRECAUTIONS.

- Unscrew the nut (**Fig. 12-C**) at the bottom of the injection assembly and put it onto the tube.
- Slide the tube onto the barb as far as it will go, tighten the clamp.

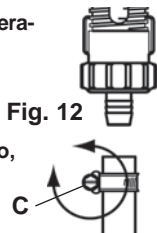

Fig. 12

ADJUSTING THE INJECTION RATE (with pressure off)

IMPORTANT ! Use no tools. Adjustment must be made when there is no pressure in the Dosatron.

- Bring the bypass button into the median position.
- Unscrew the blocking nut (**Fig. 13-B**).
- Keep it fixed while screwing or unscrewing the transparent ring (**Fig. 13-D**).
- Adjust the guide mark (black line) of the transparent ring on the chosen dosage.
- Tighten the blocking nut (**Fig. 13-B**).

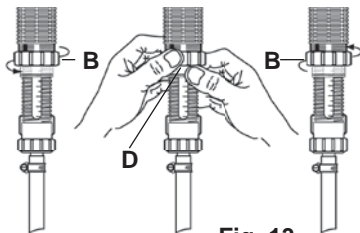

Fig. 13

REMINDER: The quantity of injected product is proportional to the quantity of water entering the Dosatron. 1% \Rightarrow 1/100, which means 100 volumes of water + 1 volume of injected products.

CHANGING SEALS IN THE INJECTION ASSEMBLY (with pres-

Frequency : Once per year.

IMPORTANT ! Use no tool or metallic utensils

ADVICE: Before dismantling any part of the injection assembly it is advisable to operate the Dosatron, injecting clean water so as to rinse through the injection system. In this way, risks of contact with concentrated solutions in the injection assembly are minimized. During any such intervention, wear protective eyewear and gloves !

METHOD OF REMOVING SEAL

Fig. 14 : Between finger and thumb, pinch the component and the seal ; push towards one side to deform the seal.

Fig. 15 : Increase the deformation to grip the part of the seal thus exposed and pull it out of its groove. Clean the seal seating without any tools. Refitting is done by hand. It is very important that the seal is not twisted once in place as this would impair its efficiency.



CHANGING SEALS IN THE INJECTION ASSEMBLY (cont...)

CHANGING THE INJECTION SEALS

- Turn off the water supply and allow the pressure to drop to zero.
- Follow the dismantling instructions as described before.
- Grease the seal with silicone (**Fig. 16-J**).
- Re-assemble in the reverse order to the above **by hand**.

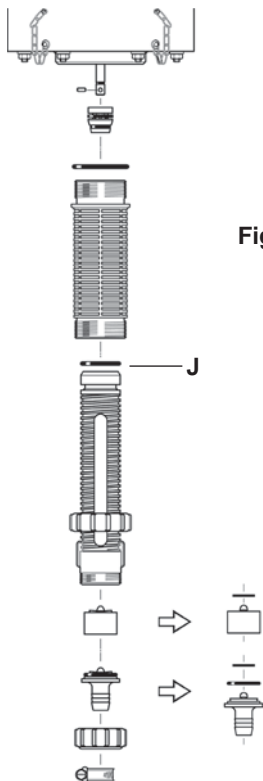
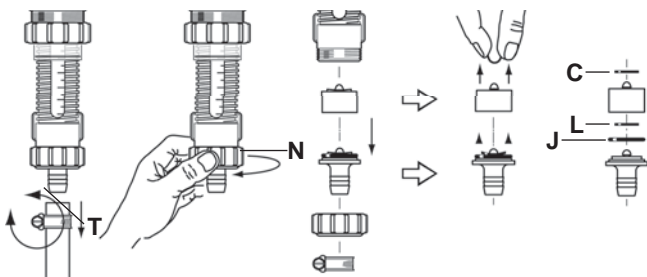

Fig. 16

CLEANING AND RE-ASSEMBLING THE SUCTION VALVE SEAL

- Turn off the water supply and allow the pressure to drop to zero.
- Loosen the clamp on the suction hose with a screwdriver (**Fig. 17-T**) and remove the suction hose.
- Unscrew and remove the black nut (**Fig. 17-N**).
- Pull downwards to remove the suction valve assembly.
- Remove the seal on top of the short valve (**Fig. 17-C**) and replace it. Turn it around the nipple in order to be sure about its correct seating. Take care not to damage the listel.
- Proceed in the same way to change the seal of the long valve (**Fig. 17-L**).
- Also change the o-ring (**Fig. 17-J**).
- Re-assemble in the reverse order to the above **by hand**.

Fig. 17



Reference Designation

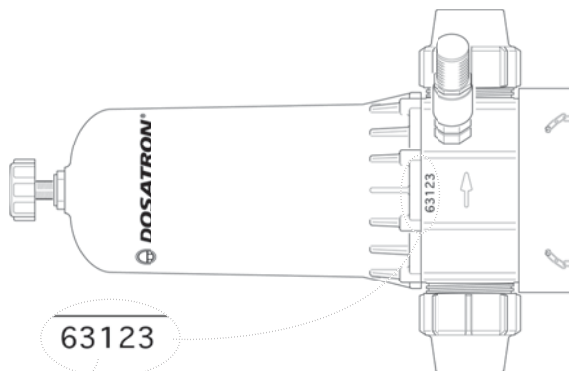

Ref. / Serial #

REF. / Serial # :							
EXAMPLE	D20	S/GL	BP	2	AF	P*	ii
Type of Dosatron							
S : Adjustable							
GL : Green Line (fertilization) [green]							
BP : integrated by-pass							
Dosage (% or ratio)							
Dosing seals :							
AF = PH 7-14							
VF = PH 1-7							
Colour : - = Blue P = Red							
Other extensions (consult us)							

* Firefighting

Troubleshooting

SYMPTOM	CAUSE	SOLUTION
Motor piston		
Dosatron does not start or stops		Check that your installation allows your unit to operate correctly
		Check that the water supply is open and that the solenoid valves are supplied with power
	The units has not been bled	Refer § Putting into Order
	The bypass is closed or half open	Open the bypass. Refer § Incorporated bypass
	Maximum flow exceeded	Reduce flow restart unit
	Damage inside the unit	
Injection		
Water flowing back into concentrate container	Contaminated, worn, or missing check valve parts	Clean or replace them
No suction of concentrate	The piston motor has stopped	See Motor piston section
	Check the suction height (4< m)	Reduce the suction height if necessary
	Air leak (inlet) in the suction tube	Check the tightness between nut and suction hose
	Blocked suction tube or clogged strainer	Clean these parts. Attention: Do not put the strainer on the ground of the tank (min. distance 10 cm)

SYMPTOM	CAUSE	SOLUTION
Injection		
Under injection	Suction of air	1. Check if all nuts of the dosing parts are correctly tightened 2. Check the condition of the suction hose
	Suction hose not sufficiently bled (air inside)	Bleed the suction hose
	Maximum flow exceeded (cavitation)	Reduce flow
	Worn plunger seal	Replace it
	Worn injection stem	Replace it
Leaks		
Leaking connectors	Seal is not correctly sitting or cut	Replace it or refit it correctly
	Hose not correctly fitted	Replace it or refit it correctly

**THE MANUFACTURER
DECLINES ALL RESPONSIBILITY IF THE DOSATRON
IS USED IN CONDITIONS THAT DO NOT CORRESPOND
TO THE OPERATING INSTRUCTIONS AS INDICATED
IN THIS MANUAL**

Limited warranty

DOSATRON INTERNATIONAL S.A.S. will provide for replacement of all parts shown to be defective in material or workmanship during a period of twelve months from the date of purchase by the original purchaser. To obtain warranty replacement of a part, the DOSATRON must be returned with original proof of purchase receipt to the manufacturer or authorized distributor and thereafter recognized as defective after examination by the technical services of the manufacturer or distributor.

The DOSATRON must be flushed of any chemical and sent to the manufacturer or distributor prepaid, but will be returned free of charge once repairs are made if found to be covered by the warranty.

Any repairs made under warranty will not extend the initial warranty period. This warranty only covers circumstances where the part has failed due to defects caused by the manufacturing process.

This warranty is invalid if the defects are found to be due to the product's misuse, inappropriate use of tools, lack of maintenance or defective installation or environmental accidents or corrosion by foreign bodies and liquids found within or in proximity to the DOSATRON.

Before using any aggressive chemicals, please consult your distributor to confirm compatibility with the dosing

pump. The seals and "o-rings" are not covered under warranty, nor is damage to the DOSATRON caused by water impurities such as sand.

A filter (ex.: 300 mesh - 60 microns depending on your water quality) must be used in front of the DOSATRON for the warranty to be valid.

DOSATRON INTERNATIONAL S.A.S. declines any responsibility if the DOSATRON is not used in compliance with the operating instructions and tolerances as indicated in this owner's manual.

This warranty gives you specific legal rights and you may also have other rights which vary from state to state. But any implied warranty or merchantability or fitness for a particular purpose applicable to this product is limited in duration to the time period of this written warranty or any implied warranty.

The manufacturer or authorized distributor shall not be liable for incidental or consequential damage, such as any economic loss, resulting from breach of this written warranty or any implied warranty. There are no warranties, express or implied, which extend beyond those described above, relating in any way to products used in conjunction with DOSATRON INTERNATIONAL S.A.S. products.

Don't hesitate to call your distributor or Dosatron for any after sales service.

KNOW YOUR FLOW

A SIMPLE METHOD

THE DOSATRON IS COMPOSED OF:

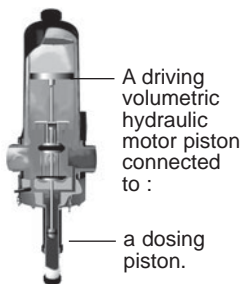

In its up and down movement, you can hear the motor piston click



2 clicks = 1 motor cycle
= The stroke volume

Once in the up position

Once in the down position

The speed of the motor is proportional to the flow of water passing through the system.

■ Calculation of water flow in l/h =

$$\frac{\text{Number of clicks in 15 seconds}}{\text{②} \text{ — 2 clicks = 1 cycle}} \times \text{④} \times \text{⑥0} \times \text{⑤}$$

Calculation for 1 minute (points to 4)
Calculation for 1 hour (points to 60)
Stroke volume in litres (points to 5)

■ Calculation of water flow in GPM =

$$\frac{\text{Number of clicks in 15 seconds}}{\text{②} \text{ — 2 clicks = 1 cycle}} \times \text{④} \times \text{⑤} \div \text{③.8}$$

Calculation for 1 minute (points to 4)
Stroke volume in litres (points to 5)
Conversion from litres to gallons (points to 3.8)

NOTA : This method of calculation cannot replace a flow meter. It is given only as an approximate guide.

Pertes de charges - Pressure loss - Druckverlust > in PSI

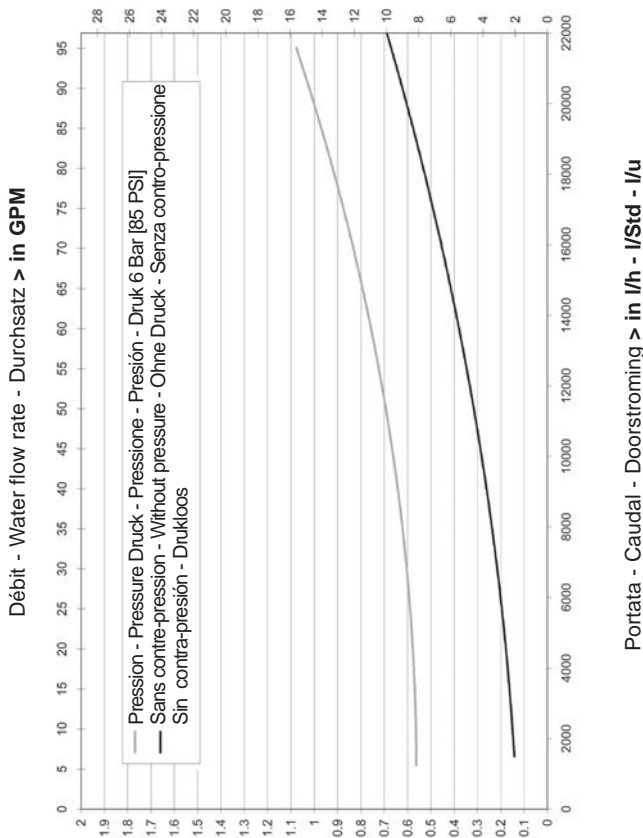

Perdite di carico - Perdidas de carga - Drukverlies > in Bar (kgf/cm²)

Ce document ne constitue pas un engagement contractuel et n'est fourni qu'à titre indicatif.
La Société DOSATRON INTERNATIONAL se réserve le droit de modifier ses appareils à tout moment.

This document does not form a contractual engagement on the part of DOSATRON INTERNATIONAL and is for information only.
The company DOSATRON INTERNATIONAL reserves the right to alter product specification or appearance without prior notice.

Dieses Dokument ist kein bindender Vertragsbestandteil und dient nur zu Informationszwecken.
Das Unternehmen DOSATRON INTERNATIONAL behält sich das Recht vor, seine Geräte jederzeit zu verändern.

Questo documento non costituisce un documento contrattuale e viene fornito soltanto a titolo indicativo.
La società DOSATRON INTERNATIONAL si riserva il diritto di modificare i propri apparecchi in qualsiasi momento.

Este documento no constituye un compromiso contractual y se suministra solamente a título orientativo.
La sociedad DOSATRON INTERNATIONAL se reserva el derecho de modificar sus aparatos en cualquier momento.

Dit document vormt geen contractuele verbintenis en wordt enkel ter informatie gegeven.
DOSATRON INTERNATIONAL behoudt zich het recht voor zijn toestellen op elk ogenblik zonder voorafgaande informatie te wijzigen.

CE Conformity Statement
Document N° DOCE05050106
This Dosatron is in compliance with the European Directive 2006/42/CE. This declaration is only valid for countries of the European Community (CE).



DOSATRON®

WATER POWERED DOSING TECHNOLOGY



FABRIQUÉ PAR
MANUFACTURED BY
HERGESTELLT VON
FABBRICATO DA
FABRICADO POR
GEPRODUCEERD DOOR

DOSATRON INTERNATIONAL S.A.S.

Rue Pascal - B.P. 6 - 33370 TRESSES (BORDEAUX) - FRANCE

Tel. 33 (0)5 57 97 11 11

Fax. 33 (0)5 57 97 11 29 / 33 (0)5 57 97 10 85

e.mail : info@dosatron.com - <http://www.dosatron.com>

© DOSATRON INTERNATIONAL S.A.S. 2009